

FED. RD. DIST. NO.	STATE	FEDERAL AID PROJECT	FISCAL YEAR	2A 13
10	OHIO		1940	

HOCKING COUNTY
S.H. 360 SEC. LOGAN (PT.), F & D (PT.)

LONGITUDINAL JOINTS

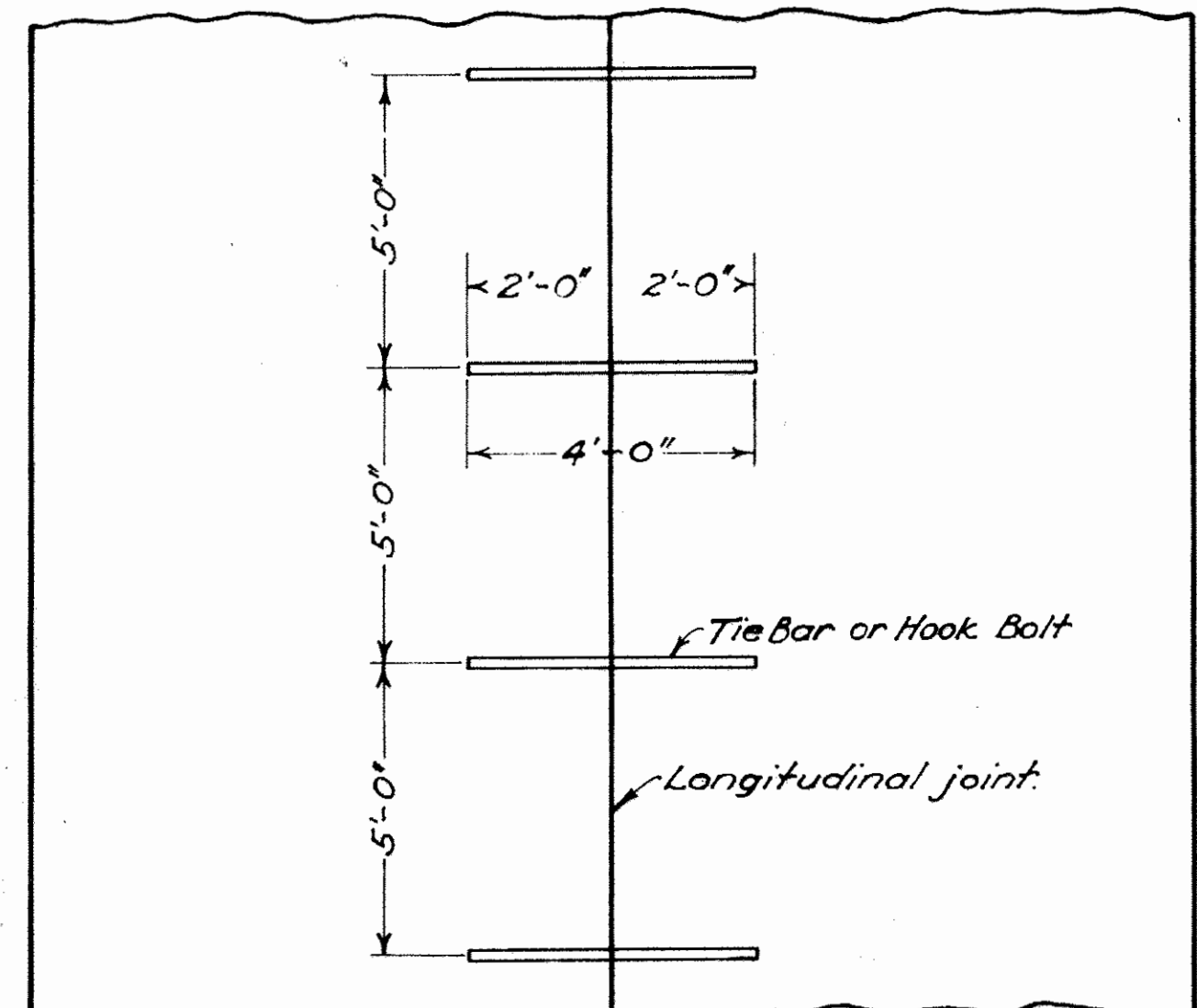

HALF PLAN FOR PAV'T. HALF PLAN FOR BASE

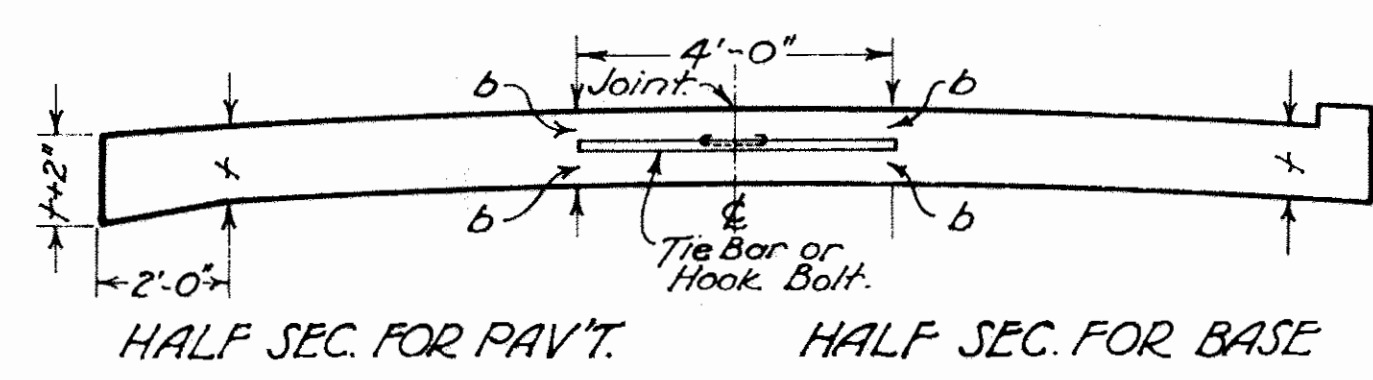

HALF SEC. FOR PAV'T. HALF SEC. FOR BASE

KEY JOINT

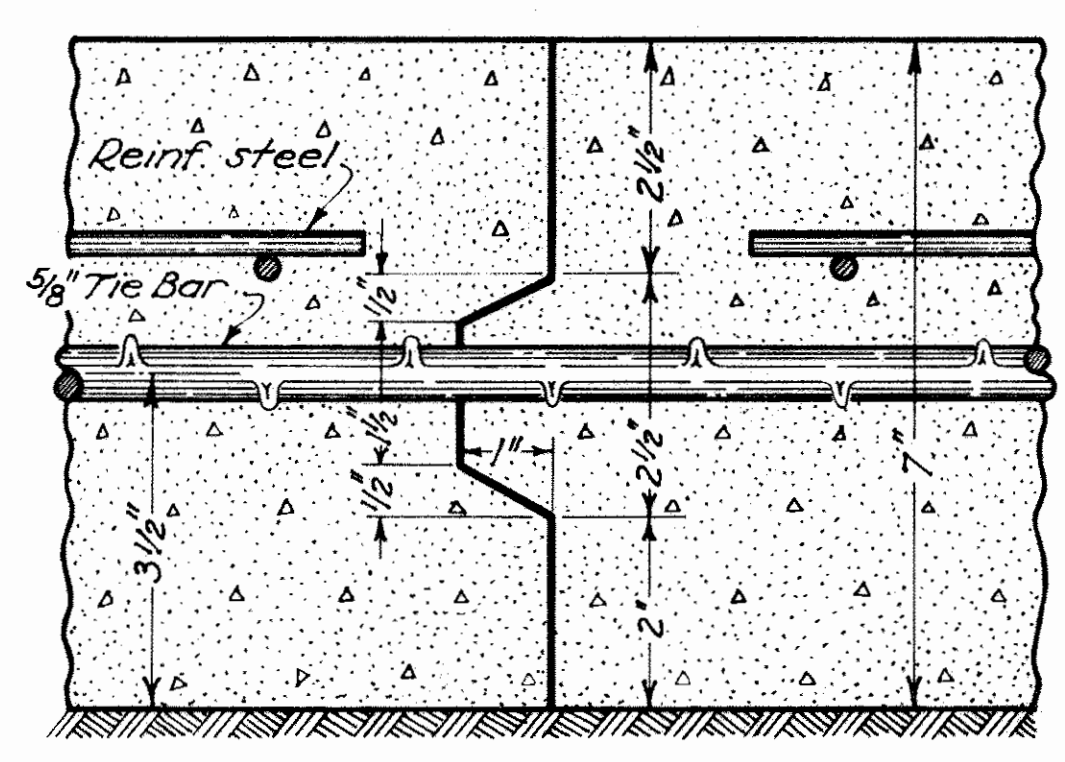

DETAIL OF JOINT

Note:—This joint is designed for 7" slab. When a greater or less thickness is used the joint shall be proportionally designed. Other deformations may be used if approved by the engineer.

METAL JOINT

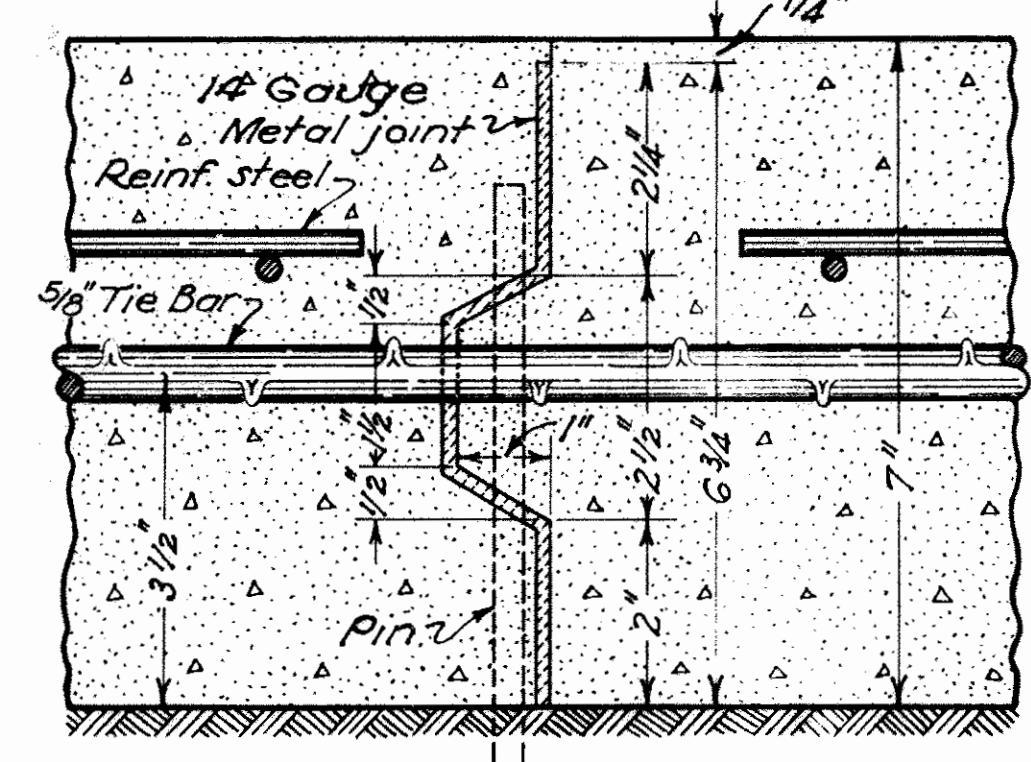

DETAIL OF JOINT

Note:—This joint is designed for 7" slab. When a greater or less thickness is used the joint shall be proportionally designed to extend within 1/2" of the surface of the slab. Other deformations may be used if approved by the engineer.

IMPRESSED JOINT

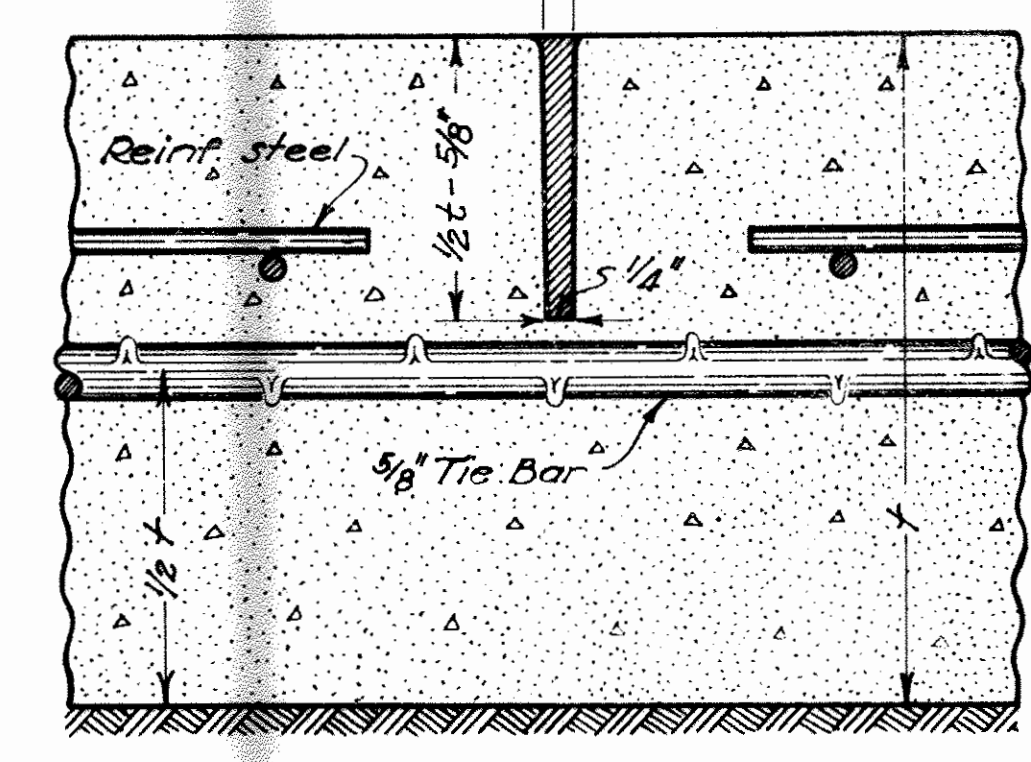

DETAIL OF JOINT

DESCRIPTION:—This joint shall be formed by impressing a device or bar into the newly deposited concrete before initial setting. The device or bar shall be removed as soon as the concrete is in such condition as to preclude of distortion or injury to the concrete. The groove thus formed shall be on the center line unless otherwise shown on the plans, and of the dimensions as detailed above. After the joint is formed it must be protected from dirt and foreign matter until the filler is placed. The filler shall be handled in such a manner that it will be confined to the joint and in no wise mar the surface.

GENERAL—Longitudinal joints shall be used when called for on the typical section, and shall be constructed as shown on this sheet.
Tie bars to be 3/8 inch round, deformed bars.
A satisfactory device shall be used to hold the tie bars in proper position.
The longitudinal joint between adjoining slabs poured in separate operations shall be a key joint with American hook bolts or equal, or billet steel (Sec. M-7.1) tie bars, unless otherwise shown on the plans.
If tie bars are bent, no portion of the bend shall extend into the first slab poured.
Immediately prior to placing the second slab, bent tie bars shall be straightened by means of a pipe slipped over the free end of the bar.
Key joints used in part width construction shall be painted with two coats of bituminous material as per Section M-5.5-F-2 before adjoining slabs are poured.
The Metal, Key, and 1/8" Premolded Joints shall not be edged.
Special care shall be exercised in edging Impressed and 3/8" Premolded Joints, that the width of the opening does not exceed that shown.

Material for sealing 3/8 inch premolded joints and for filling impressed joints shall meet the requirements of Section M-5.5-F-2. Immediately before placing liquid bituminous seal or filler an application of kerosene shall be applied to the area of the joint to be in contact with the seal or filler. Application of kerosene shall be by pressure spray, brush or swab.

PREMOLDED JOINT

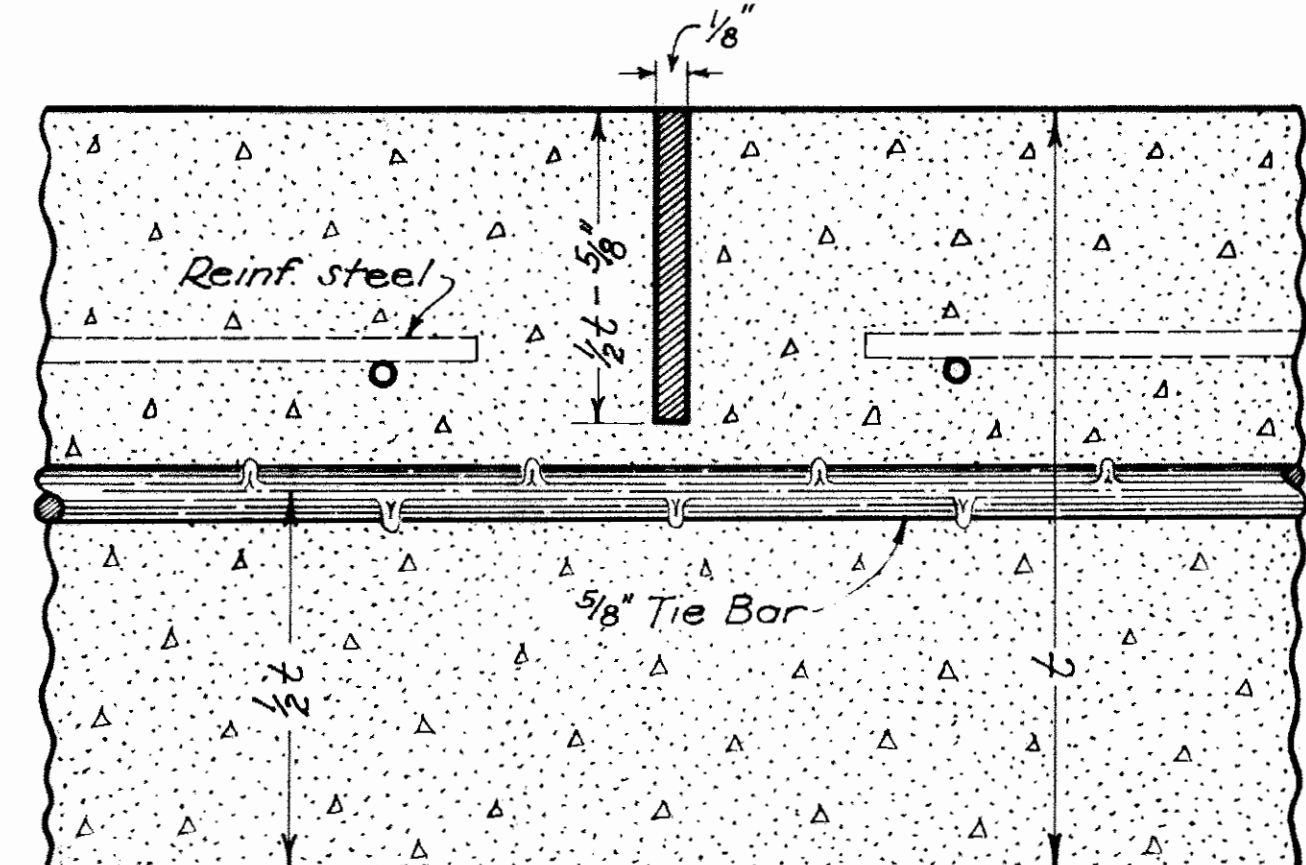

PREMOLDED JOINT

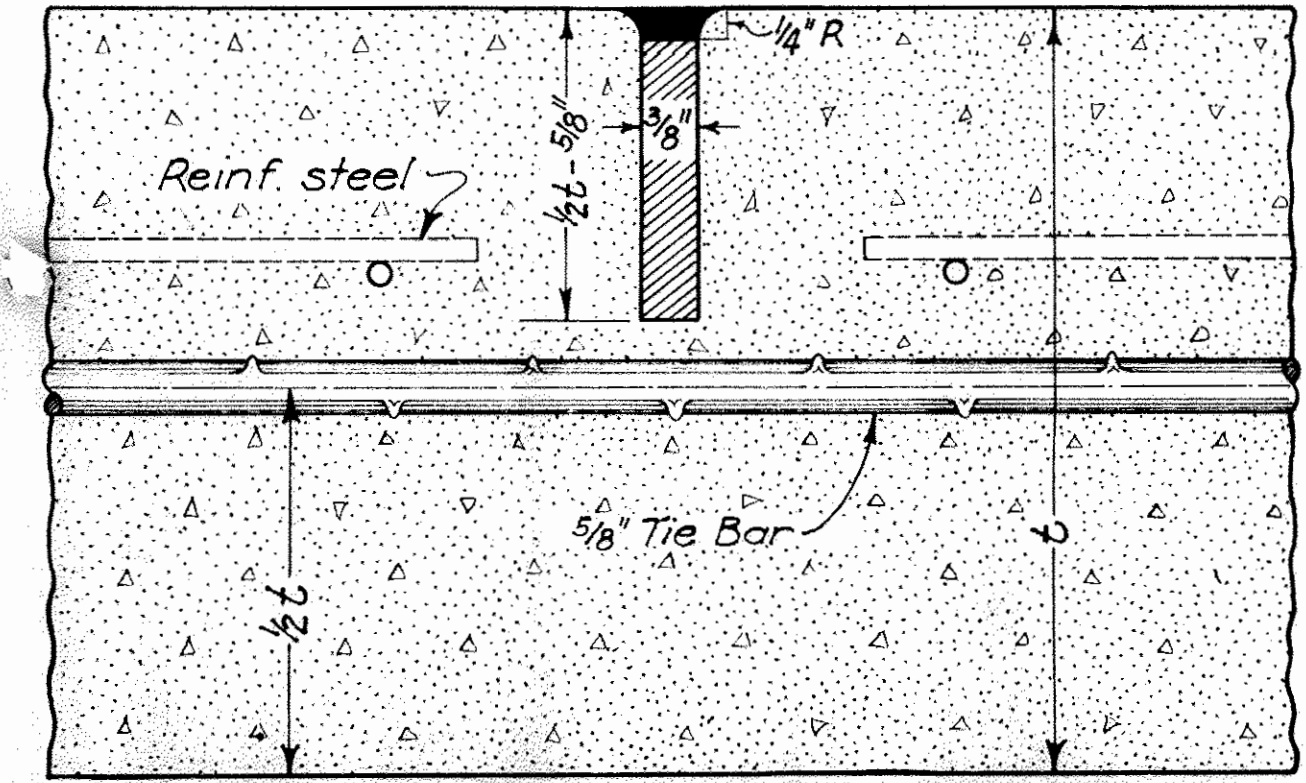

EXPANSION BOLT JOINT

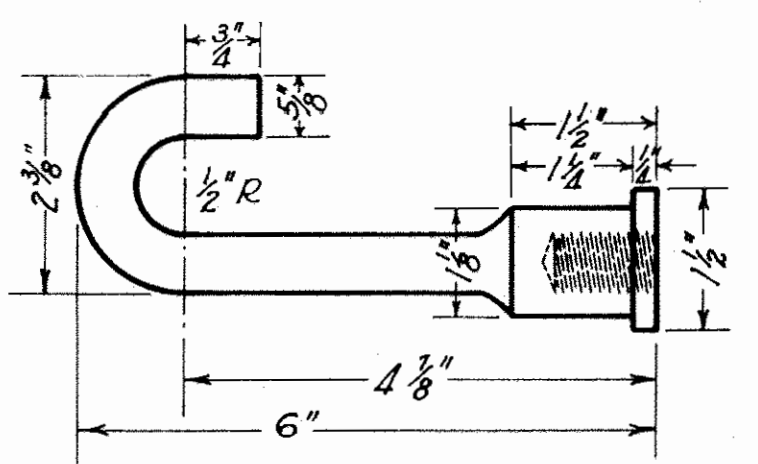
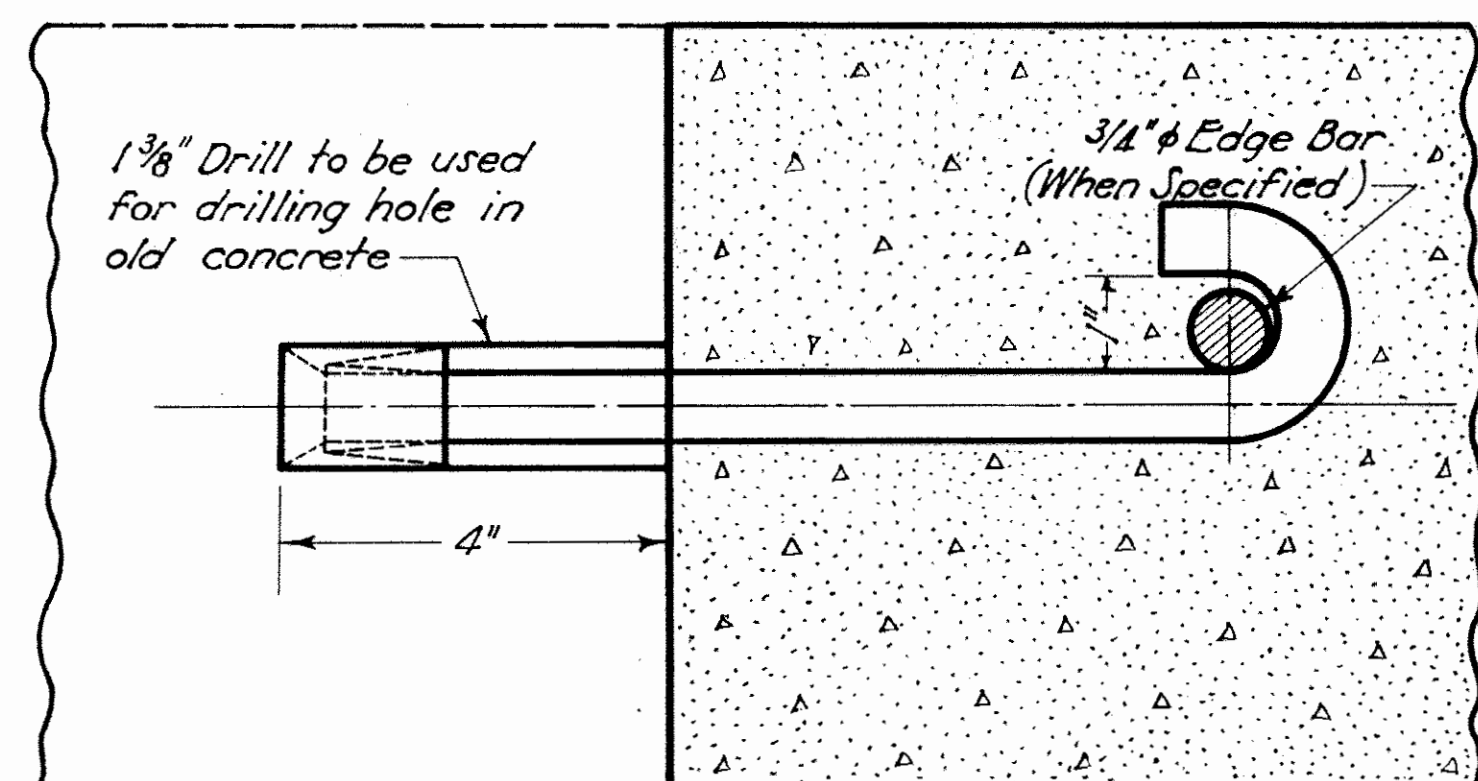

INSERT

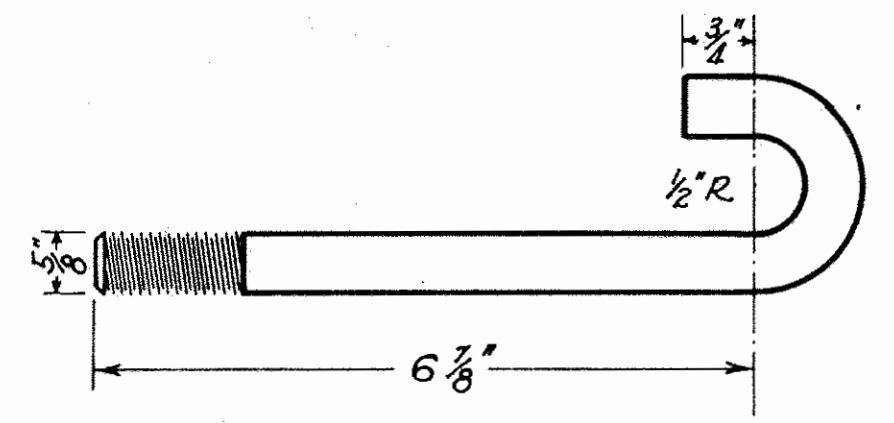

J BOLT

HOOK BOLT DETAIL

HOOK BOLT AND KEY JOINT

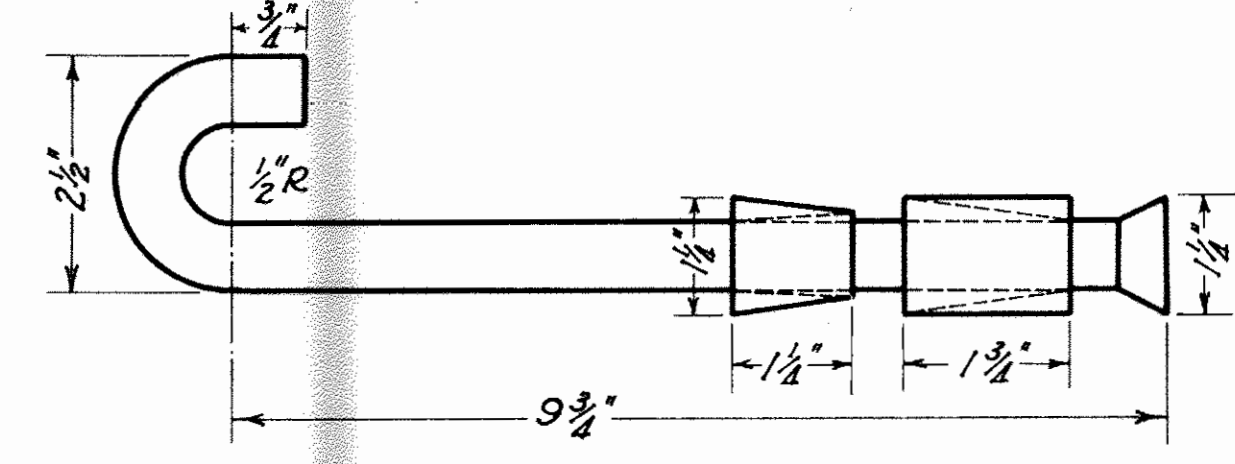
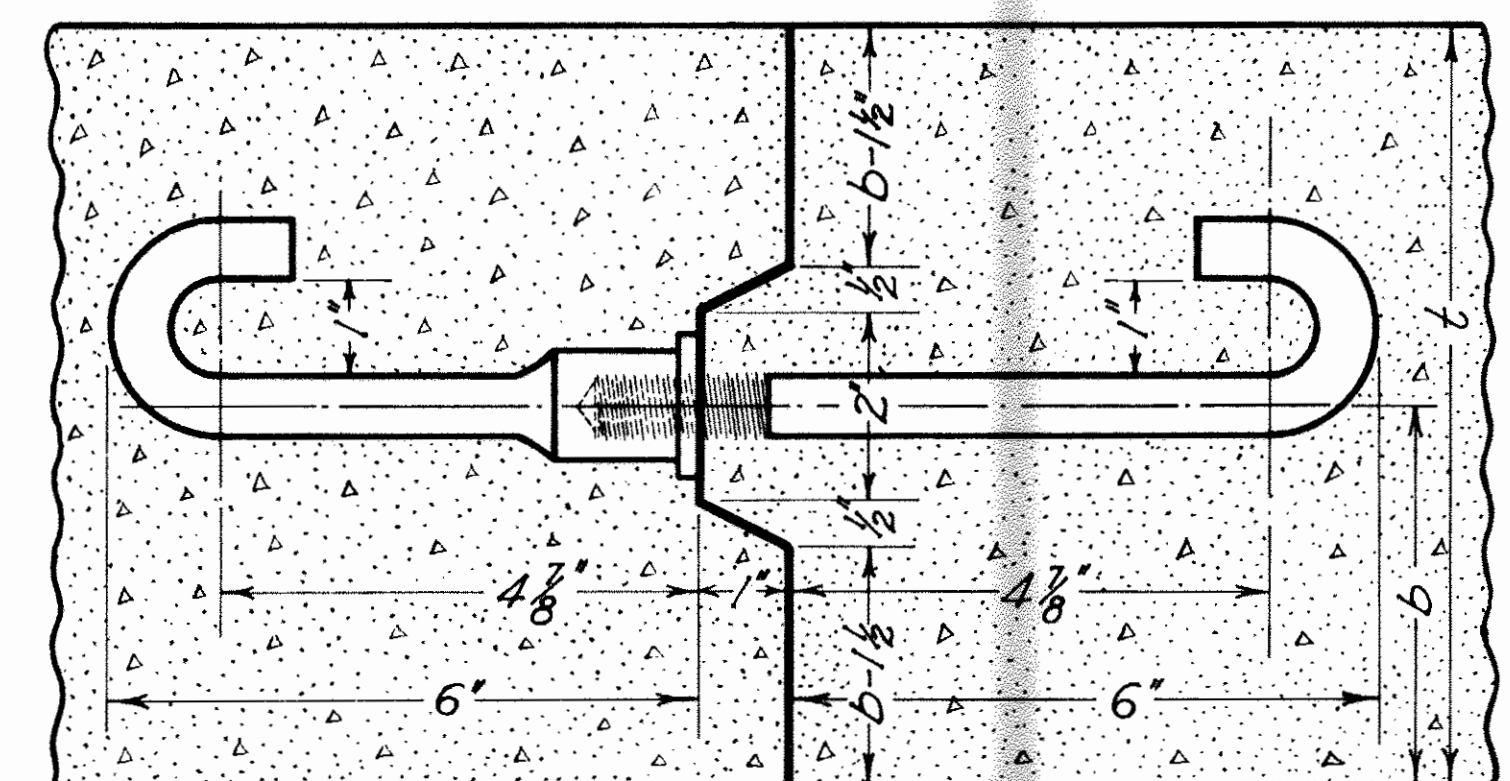

EXPANSION BOLT DETAIL

ACCEPTABLE METHOD OF FORMING JOINT

