

WINGWALL ELEVATION
(FOOTING NOT SHOWN)

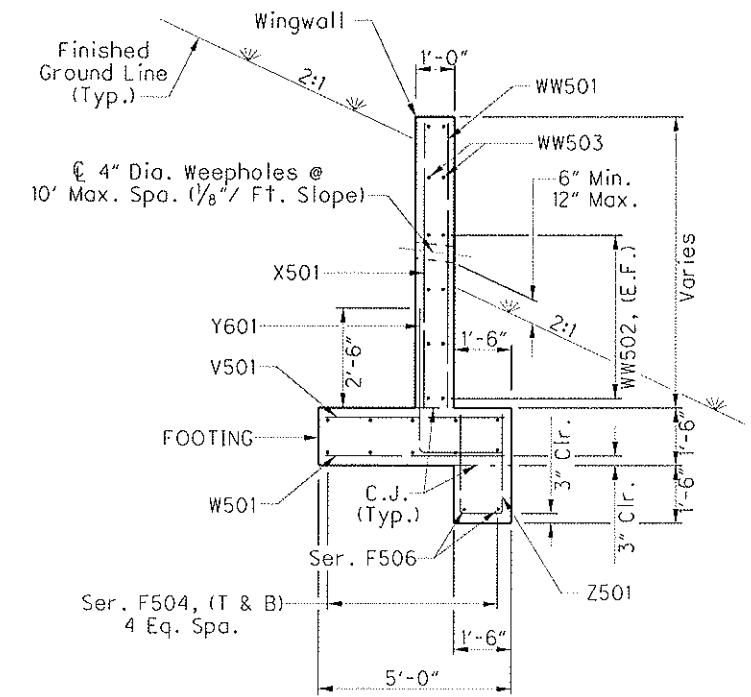

SECTION C-C
(POROUS BACKFILL NOT SHOWN FOR CLARITY)

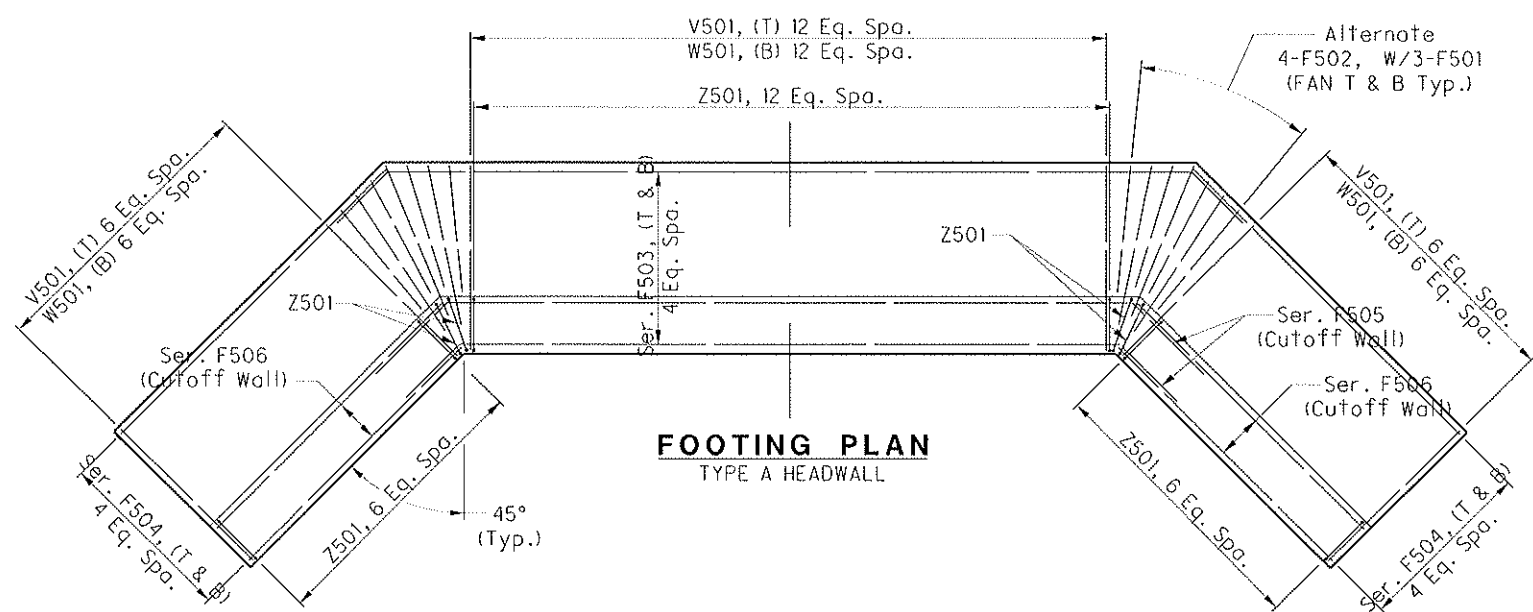

FOOTING PLAN
TYPE A HEADWALL

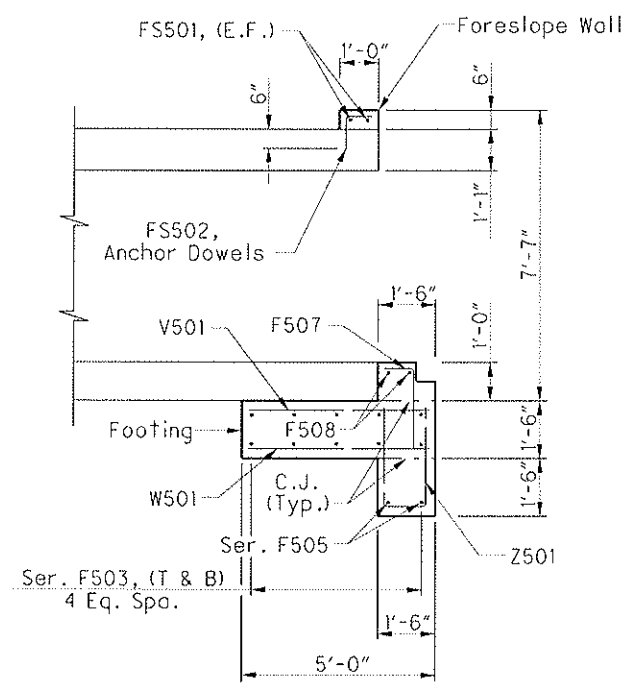

SECTION D-D
CULVERT OUTLET BEVEL SHOWN

- NOTES**
- FOR CULVERT SITE PLAN, SEE SHEET 1/6.
 - FOR PRECAST BOX CULVERT DETAILS, SEE SHEET 3/6.
 - THE BAR SIZE NUMBER IS SPECIFIED ON THE PLANS IN THE BAR MARK COLUMN. THE FIRST DIGIT INDICATES THE BAR SIZE NUMBER. FOR EXAMPLE, WW501 IS A No. 5 BAR. BAR DIMENSIONS SHOWN ARE OUT TO OUT. ALL REINFORCING STEEL SHALL BE EPOXY COATED.
 - THE LAP SPLICE LENGTHS USED IN THESE DETAILS ARE AS FOLLOWS: 2'-5" FOR No. 5 BARS; 2'-11" FOR No. 6 BARS.

LEGEND:

C.J.	CONSTRUCTION JOINT	N.F.	NEAR FACE
Clr.	CLEAR	Ser.	SERIES
Dia.	DIAMETER	STR	STRAIGHT
E.F.	EACH FACE	(T)	TOP
F.F.	FAR FACE	(B)	BOTTOM
Max.	MAXIMUM	(T & B)	TOP AND BOTTOM
Min.	MINIMUM	Typ.	TYPICAL
PEJF	PREFORMED EXPANSION JOINT FILLER	Inc.	INCREMENT